

PRORIL

60 Hz

Designed for light weight, excellent performance, low energy consumption, and easy maintenance, PRORIL submersible handy pumps serve a wide range of pumping applications on utility, construction, industrial, and municipal job sites.

Handy and Residue Pump

SAVVY 300

Handy Pump



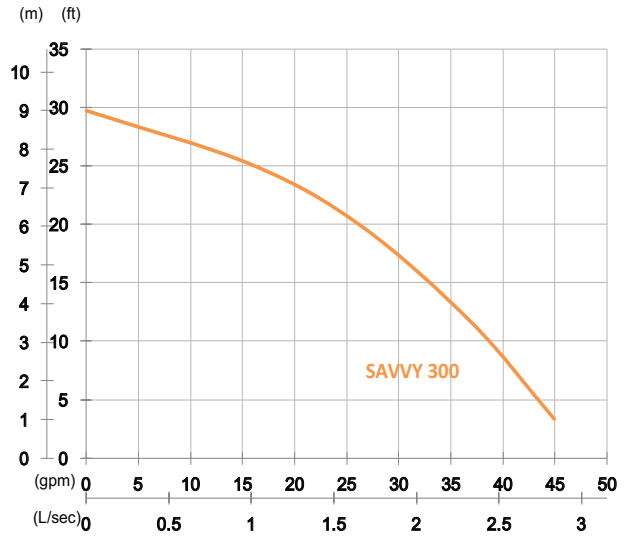

Shaft Speed : 3450 rpm

Outlet : 50mm, 2in

OUTPUT	HEAD	FLOW
0.25 kW	Rated : 6m, 20ft	Rated : 1.7 L/s, 26 gpm
0.33 HP	Max : 9m, 30ft	Max : 2.8 L/s, 45 gpm

Solid Passage : 6mm, 0.2in

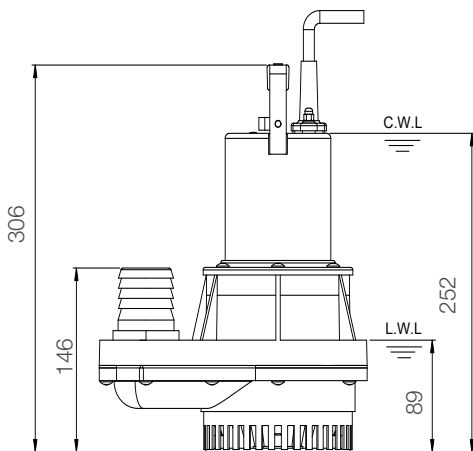
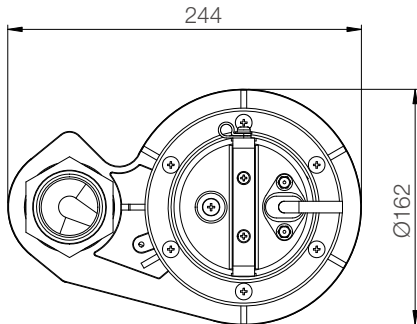

unit : mm

Weight : 4kg / 9 lbs

Pump Type		Electric Submersible Pumps
		1-Phase
Motor	Type	Induction Motor
	Poles	2 Pole
	Insulation	Class F
	Protector	Miniature Thermal Protector
	Starter	Capacitor-Run
Lubricant		Food Grade (ISO VG115)
Impeller Type		Vortex
Shaft Seal		Single Mechanical Seal Ceramic / Carbon
Bearings		C3 Shielded ball bearings
Cable		PVC (CSA Certified) / H05RN-F 3m (10ft) or longer upon request.
Materials	Pump Casing	Synthetic Polymers
	Impeller	Synthetic Polymers
	Motor Frame	Stainless Steel
	Motor Shaft	Stainless Steel
	Strainer	Synthetic Polymers
Max. Liquid Temperature		40°C (104°F)
Max. Submersion Depth		10m (33ft)
pH Range		pH 5 - pH 8